

PATENT PENDING



**2 Lamp
T5, T5HO, or T8**

APPLICATION

- Highly efficient, highly flexible recessed air handling luminaire with an upscale architectural appearance.
- Excellent visual comfort, ideal for modern high-tech. offices.
- Other applications include schools and retail environments.
- Many ballast/lamp systems are available, providing flexibility to tailor the luminaire to specific applications.
- Standard distribution works well for conventional applications, while the wide "batwing" distribution allows wider luminaire spacing and improves uniformity for more even lighting.
- High optical efficiency increases energy savings.
- Step dimming ballasts can be switched to less than 50% input power for energy savings to meet most energy codes while maintaining symmetrical illumination.
- Multiple shielding options create a wide variety of photometric variations and aesthetic effects.
- Specific models are available for Grid, Flange, Z-spline/Modular or Screw Slot ceiling systems.
- Designed for air supply/return through side slots in reveal.

- Black reveal around enclosure provides floating appearance and disguises air slots. White reveal is available.
- Wireway cover is easily removable without tools for quick ballast or wiring access from below.
- Integral T-bar grid clips are built into luminaire ends.
- K.O. in luminaire ends for thru wiring or conduit entry in shallow plenums.

ELECTRICAL

- UL listed for damp locations. Canadian certified optional.
- Standard size fluorescent emergency ballasts can be incorporated, UL listed for dry locations.
- Systems are available offering electrical system efficacy ratings up to 102 Lumens/Watt.

ENCLOSURES

- One-piece enclosure hinges down as an assembly for easy access to lamps and ballast from below.
- T-hinges provide secure retention of enclosure and eliminate non-captive parts to hold during servicing.
- Guide-post spring loaded latches allow easy opening and closing of the enclosure.
- Choice of shielding includes diffuse acrylic with or without overlay, white radial louver with overlay, round or linear perforated steel with overlay.

CONSTRUCTION/FINISH

- One piece die-formed embossed steel housing provides added rigidity, resists damage during shipment/handling.

CATALOG NUMBER



FAMILY		CEILING TYPE		NO. OF LAMPS		DIFFUSERS		BALLAST CONFIG.		OPTIONS	
AT – Attune		G – Grid F – Flange Z – Z Spline/Modular T – Screw Slot		(not included) 2		D – Diffuse DO – Diffuse w/overlay WO – White Radial Louver w/overlay PMW – Round Perf. w/white overlay SMW – Slotted (Linear) Perf. w/white overlay		1/2 – One 2-lamp ballast		APC – Adjustable Air Pattern Control Blades ASC – Air Slot Covers CM – Canadian Market CC – Custom Color F1 – 3/8" flex, 3 wire 18 gauge F2 – 3/8" flex, 4 wire 18 gauge E1* – DEB-1 emerg. ballast, T8 lamps, 350-450 lumens E7* – DEB-7 emerg. ballast, T8 lamps, 600-700 lumens E5* – DEB-5 emerg. ballast, T8 lamps 1100-1400 lumens E7LP* – DEB-7LP emerg. ballast T5/T5HO, 430-700 lumens E6* – DEB-6LP emerg. ballast, T5/T5HO lamps, 750-1325 lumens GLR# – Fusing, fast blow (# = number of ballasts) LPT730 – Installed T8 lamps, 70+ CRI, 3000K LPT735 – Installed T8 lamps, 70+ CRI, 3500K LPT741 – Installed T8 lamps, 70+ CRI, 4100K LPT830HL – Installed T8 hi lumen lamps, 80+ CRI, 3000K LPT835HL – Installed T8 hi lumen lamps, 80+ CRI, 3500K LPT841HL – Installed T8 hi lumen lamps, 80+ CRI, 4100K LPT830 – Installed T8/T5/T5HO lamps, 80+ CRI, 3000K LPT835 – Installed T8/T5/T5HO lamps, 80+ CRI, 3500K LPT841 – Installed T8/T5/T5HO lamps, 80+ CRI, 4100K PAF – Housing painted after stamping WR – White Reveal	
WIDTH		DISTRIBUTION		AIR FUNCTION		LAMP TYPE/WATTAGE		VOLTAGE			
2 – 2'		N – Standard W – Wide (Batwing)		A – Air Supply/Return		28 – 28wT5 (46") 32 – 32wT8 (48") 54HO – 54wT5HO (46")		120 277 347 UNV – Universal Voltage, 120-277 volt			
BALLAST TYPE											
EB95 – 28wT5 Electronic ballast, .95 ballast factor EB115 – 28wT5 Electronic ballast, 1.15 ballast factor EBS95 – 28wT5 Electronic step dimming ballast, .95 ballast factor EBS115 – 28wT5 Electronic step dimming ballast, 1.15 ballast factor EBS80 – 54wT5HO Electronic step dimming ballast, .80 ballast factor EBD – T5/T5HO/T8 electronic dimming ballast EB – T5/T5HO/T8 electronic ballast, std. ballast factor EBL – T8 Electronic ballast, low ballast factor EBH – T8 Electronic ballast, hi ballast factor EB10I – T8 Electronic ballast, <10% THD, instant start EB10R – T8 Electronic ballast, <10% THD, rapid start EBS80 – T8 Electronic step dimming ballast											

*Factory installed

JOB INFORMATION

0019.1-AR

ENERGY DATA

Lamp Type	Ballast Type	Input Power (120/277V)	Electrical System Lumens/Watt	
			Std. Lamps*	Hi-lumen Lamps
28	EB95	60W / 58W	95	-
	EBSD95@hi	60W / 58W	95	-
	EBSD95@lo	28W / 28W	73	-
	EB115	72W / 71W	94	-
	EBSD115@hi	72W / 71W	94	-
	EBSD115@lo	35W / 35W	80	-
	EB	66W / 64W	95	-
32	EB	58W / 58W	85	94
	EB10I	59W / 58W	85	94
	EB10R	62W / 60W	82	91
	EBL	47W / 47W	92	102
	EBH	77W / 77W	87	97
	EBSD@hi	57W / 56W	88	97
	EBSD@lo	28W / 28W	60	66
54HO	EB	120W / 117W	85	-
	EBSD80@hi	96W / 93W	86	-
	EBSD80@lo	52W / 51W	78	-

*Standard lamp T8 values assume 70+CRI 32W lamp. 80+CRI lamps or energy saving lamps are also available.

DIMENSIONS

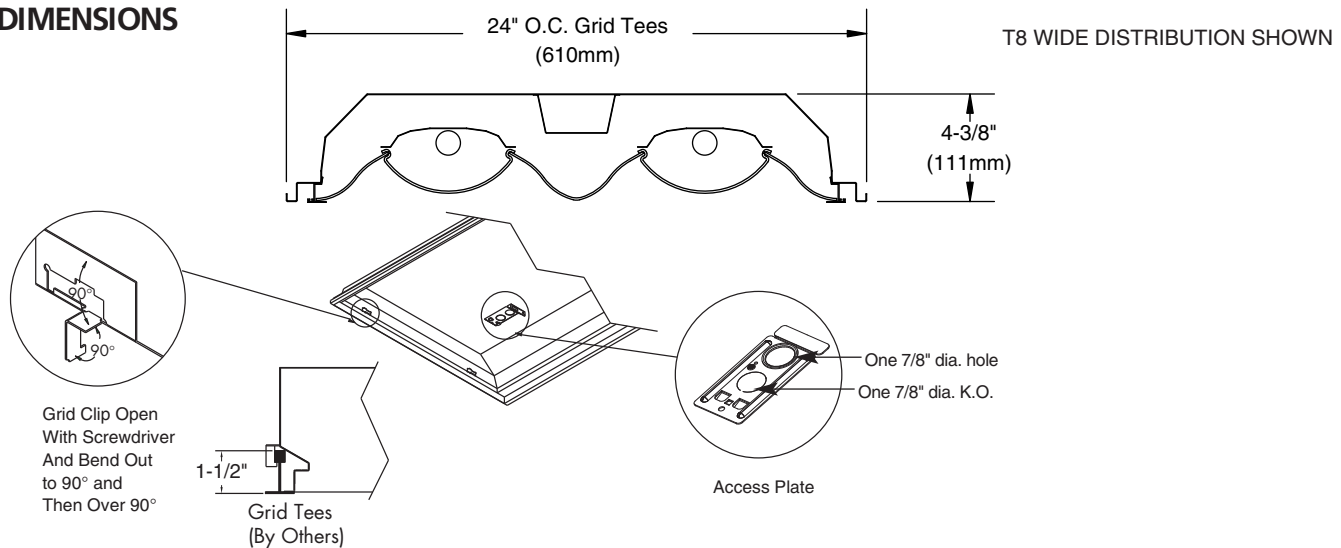

2 AT W G A 2 32

CEILING TYPE

G = GRID (NEMA G)
SIDE

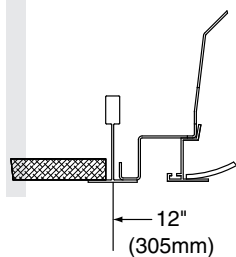

(NEMA Type G)
Lay-in acoustical ceilings using exposed grid suspension, with tees for fixtures on 24" x 48" spacing.

F = FLANGE (NEMA F)
SIDE

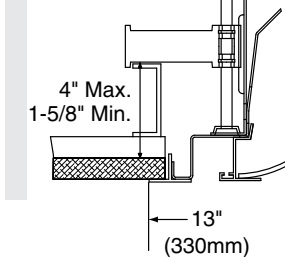

(NEMA Type F)
Flange for acoustical ceilings using concealed mechanical suspension. Swing-jack mounting brackets: adjustment 4" max. and 1-5/8" min. Refer to sheet 801-CL for cut-out information.

T = SCREW SLOT (NEMA SS)
SIDE

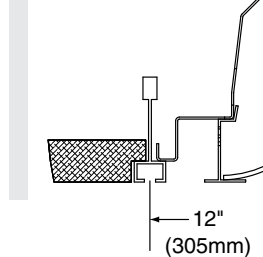

(NEMA Type SS)
Typical Screw Slot Ceiling System. Bottom of enclosure is flush with ceiling plane.

Z = (NEMA M/Z) MODULAR AND "Z" SPLINE
SIDE

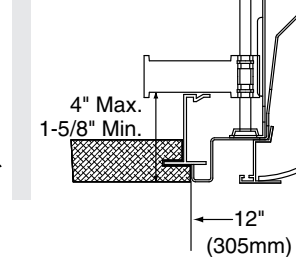

(NEMA M/Z)
Modular and "Z" Spline using concealed mechanical suspension. Swing-jack mounting brackets: adjustment 4" max. and 1-5/8" min.

PHOTOMETRIC DATA

CATALOG # 2ATWGA228-D-1/2-EB
TEST #25469 S/MH=1.5

LAMPS = F28T5
BALLAST = ELECTRONIC

INPUT WATTS = 67
BALLAST FACTOR = 1.00

LER = 70

COMPARATIVE YEARLY LIGHTING ENERGY COST PER 1000 LUMENS = \$3.43 BASED ON 3000 HRS. AND \$.08 PER KWH.

FIXTURE EFFICIENCY= 90.2%

T5 WIDE, DIFFUSE

CANDLEPOWER				
Angle	End	45	Cross	
0	1510	1510	1510	
5	1520	1522	1515	
10	1501	1543	1579	
15	1467	1569	1649	
20	1422	1584	1699	
25	1362	1577	1699	
30	1288	1540	1639	
35	1200	1459	1527	
40	1095	1348	1378	
45	982	1210	1218	
50	854	1057	1059	
55	726	897	901	
60	594	747	737	
65	467	590	551	
70	342	428	348	
75	230	263	185	
80	131	128	85	
85	51	35	21	

MAINTAINED ILLUMINATION TABLE- Square Feet/Fixture*			
<ul style="list-style-type: none"> 80-50-20 Reflectances (Ceiling-Wall-Floor) LLF = 0.89 2600 Lumens/Lamp very clean Room width divided by room height = 5 or more, 2 or 1 			
Fixture Size & # of Lamps	Room Width Room Height =	Approx. Area (sq. ft.) per Fixture	
		30 ft-c	50 ft-c
2x4	5	146	88
T5 Wide	2	100	60
Diffuse	1	73	44

*Observe Fixture S/MH Requirements for Specific Applications

COEFFICIENT OF UTILIZATION						
pfc pcc pw RCR	20		70		50	
	70	50	30	70	50	30
0	107	107	107	105	105	100
1	98	94	91	95	92	89
2	90	82	77	88	81	76
3	81	72	66	80	70	65
4	75	64	56	72	63	56
5	68	57	50	67	56	48
6	64	52	44	61	51	42
7	58	46	39	56	46	39
8	55	42	34	54	41	34
9	51	39	32	50	39	32
10	47	35	28	46	35	28

LIGHT DISTRIBUTION			
DEGREES	LUMENS	% LAMP	% FIXTURE
0-30	1304	25.1	27.8
0-40	2184	42.0	46.6
0-60	3840	73.9	81.9
0-90	4691	90.2	100.0

.89LLF = .94LDD x .95LLD x 1.0BF

PHOTOMETRIC DATA

CATALOG # 2ATNGA228-D-1/2-EB
TEST #25459 S/MH=1.2

LAMPS = F28T8
BALLAST = ELECTRONIC

INPUT WATTS = 63
BALLAST FACTOR = 1.00

LER = 70

COMPARATIVE YEARLY LIGHTING ENERGY COST PER 1000 LUMENS = \$3.43 BASED ON 3000 HRS. AND \$.08 PER KWH.

FIXTURE EFFICIENCY= 85.0%

T8 STANDARD, DIFFUSE

CANDLEPOWER				
Angle	End	45	Cross	
0	1941	1941	1941	
5	1936	1936	1901	
10	1901	1901	1868	
15	1846	1845	1814	
20	1763	1768	1738	
25	1663	1666	1630	
30	1538	1542	1504	
35	1401	1398	1356	
40	1242	1246	1187	
45	1077	1080	1009	
50	911	914	834	
55	748	748	637	
60	594	595	430	
65	451	430	283	
70	323	283	185	
75	211	170	118	
80	116	88	65	
85	46	29	19	

MAINTAINED ILLUMINATION TABLE- Square Feet/Fixture*			
<ul style="list-style-type: none"> 80-50-20 Reflectances (Ceiling-Wall-Floor) LLF = 0.89 2600 Lumens/Lamp very clean Room width divided by room height = 5 or more, 2 or 1 			
Fixture Size & # of Lamps	Room Width Room Height =	Approx. Area (sq. ft.) per Fixture	
		30 ft-c	50 ft-c
2x4	5	139	83
T8 Standard	2	98	59
Diffuse	1	73	44

*Observe Fixture S/MH Requirements for Specific Applications

COEFFICIENT OF UTILIZATION						
pfc pcc pw RCR	20		70		50	
	70	50	30	70	50	30
0	101	101	101	98	98	93
1	93	90	86	91	88	84
2	85	79	73	83	78	72
3	79	70	64	77	68	63
4	72	63	56	70	61	56
5	67	56	50	65	56	48
6	61	52	44	60	51	44
7	57	46	40	56	46	40
8	54	42	35	53	41	35
9	51	40	33	48	39	33
10	46	36	29	46	35	29

LIGHT DISTRIBUTION			
DEGREES	LUMENS	% LAMP	% FIXTURE
0-30	1465	28.2	33.2
0-40	2332	44.8	52.8
0-60	3795	73.0	85.9
0-90	4417	85.0	100.0

.89LLF = .94LDD x .95LLD x 1.0BF

PHOTOMETRIC DATA

CATALOG # 2ATWGA232-D-1/2-EB
TEST #25445 S/MH=1.5

LAMPS = F32T8
BALLAST = ELECTRONIC

INPUT WATTS = 59
BALLAST FACTOR = 0.88

LER = 72

COMPARATIVE YEARLY LIGHTING ENERGY COST PER 1000 LUMENS = \$3.33 BASED ON 3000 HRS. AND \$.08 PER KWH.

FIXTURE EFFICIENCY= 84.3%

T8 WIDE, DIFFUSE

CANDLEPOWER				
Angle	End	45	Cross	
0	1524	1524	1524	
5	1535	1529	1518	
10	1515	1535	1551	
15	1480	1540	1590	
20	1433	1538	1621	
25	1372	1522	1633	
30	1300	1492	1624	
35	1210	1433	1568	
40	1102	1352	1487	
45	990	1251	1378	
50	865	1127	1236	
55	738	990	1038	
60	606	838	779	
65	477	644	526	
70	352	438	319	
75	238	255	175	
80	138	122	83	
85	54	34	22	

MAINTAINED ILLUMINATION TABLE- Square Feet/Fixture*			
<ul style="list-style-type: none"> 80-50-20 Reflectances (Ceiling-Wall-Floor) LLF = 0.75 2850 Lumens/Lamp very clean Room width divided by room height = 5 or more, 2 or 1 			
Fixture Size & # of Lamps	Room Width Room Height =	Approx. Area (sq. ft.) per Fixture	
		30 ft-c	50 ft-c
2x4	5	126	76
T8 Wide	2	86	51
Diffuse	1	62	37

*Observe Fixture S/MH Requirements for Specific Applications

COEFFICIENT OF UTILIZATION						
pfc pcc pw RCR	20		70		50	
	70	50	30	70	50	30
0	100	100	100	97	97	93
1	92	88	84	90	85	82
2	83	77	71	81	76	72
3	76	68	60	73	66	59
4	69	59	53	68	58	52
5	64	53	46	61	52	45
6	58	47	40	57	46	40
7	55	42	35	53	42	35
8	51	39	32	50	39	32
9	47	35	28	46	35	28
10	44	33	27	42	33	26

LIGHT DISTRIBUTION			
DEGREES	LUMENS	% LAMP	% FIXTURE
0-30	1279	22.4	26.6
0-40	2161	37.9	45.0
0-60	3933	69.0	81.8
0-90	4806	84.3	100.0

.75LLF = .94LDD x .91LLD x .88BF



The photometric results were obtained in the Day-Brite Lighting Laboratory which is NVLAP accredited by the National Institute of Standards and Technology.

PHOTOMETRIC DATA

CATALOG # 2ATNGA232-D-1/2-EB
TEST #25418 S/MH=1.2

LAMPS = F32T8
BALLAST = ELECTRONIC

INPUT WATTS = 60
BALLAST FACTOR = 0.88

LER = 74

COMPARATIVE YEARLY LIGHTING ENERGY COST PER 1000 LUMENS = \$3.24 BASED ON 3000 HRS. AND \$.08 PER KWH.

FIXTURE EFFICIENCY= 88.0%

T8 STANDARD, DIFFUSE

CANDLEPOWER				
Angle	End	45	Cross	
0	2052	2052	2052	
5	2063	2042	2028	
10	2026	2015	2005	
15	1966	1964	1963	
20	1886	1897	1900	
25	1783	1803	1810	
30	1651	1688	1696	
35	1512	1580	1561	
40	1353	1398	1396	
45	1179	1231	1226	
50	1005	1060	1045	
55	833	891	827	
60	666	722	595	
65	511	540	396	
70	368	362	254	
75	242	219	159	
80	137	117	86	
85	54	37	24	

MAINTAINED ILLUMINATION TABLE- Square Feet/Fixture*			
<ul style="list-style-type: none"> 80-50-20 Reflectances (Ceiling-Wall-Floor) LLF = 0.75 2850 Lumens/Lamp very clean Room width divided by room height = 5 or more, 2 or 1 			
Fixture Size & # of Lamps	Room Width Room Height =	Approx. Area (sq. ft.) per Fixture	
		30 ft-c	50 ft-c
2x4	5	133	80
T8 Standard	2	92	55
Diffuse	1	68	41

*Observe Fixture S/MH Requirements for Specific Applications

COEFFICIENT OF UTILIZATION						
pfc pcc pw RCR	20		70		50	
	70	50	30	70	50	30
0	105	105	105	102	102	97 97
1	96	93	89	93	91	88 86 84
2	89	81	76	85	80	75 77 72
3	81	71	66	79	70	65 68 63
4	75	65	56	72	63	56 60 55
5	68	57	50	67	56	50 55 48
6	64	52	45	61	52	44 50 44
7	58	47	40	57	46	40 46 39
8	55	44	35	54	42	35 41 35
9	52	40	33	50	40	33 39 32
10	47	36	29	46	36	29 35 29

LIGHT DISTRIBUTION			
DEGREES	LUMENS	% LAMP	% FIXTURE
0-30	1576	27.6	31.4
0-40	2539	44.5	50.6
0-60	4243	74.4	84.6
0-90	5017	88.0	100.0

.75LLF = .94LDD x .91LLD x .88BF

PHOTOMETRIC DATA

CATALOG # 2ATWGA232-WO-1/2-EB
TEST #25793 S/MH= 1.3

LAMPS = F32T8
BALLAST = ELECTRONIC

INPUT WATTS = 59
BALLAST FACTOR = 0.88

LER = 59

COMPARATIVE YEARLY LIGHTING ENERGY COST PER 1000 LUMENS = \$4.07 BASED ON 3000 HRS. AND \$.08 PER KWH.

FIXTURE EFFICIENCY= 69.7%

T8, RADIAL LOUVER

CANDLEPOWER				
Angle	End	45	Cross	
0	1695	1695	1695	
5	1683	1678	1676	
10	1609	1635	1674	
15	1520	1575	1666	
20	1415	1503	1644	
25	1286	1410	1586	
30	1174	1319	1504	
35	1034	1195	1404	
40	890	1064	1288	
45	742	927	1163	
50	592	790	1041	
55	437	669	906	
60	299	554	760	
65	225	454	551	
70	169	340	340	
75	121	216	130	
80	75	109	31	
85	32	47	11	

MAINTAINED ILLUMINATION TABLE- Square Feet/Fixture*			
<ul style="list-style-type: none"> 80-50-20 Reflectances (Ceiling-Wall-Floor) LLF = 0.75 2850 Lumens/Lamp very clean Room width divided by room height = 5 or more, 2 or 1 			
Fixture Size & # of Lamps	Room Width Room Height =	Approx. Area (sq. ft.) per Fixture	
		30 ft-c	50 ft-c
2x4	5	105	63
T8 Wide	2	73	44
Baffle w/overlay	1	54	32

*Observe Fixture S/MH Requirements for Specific Applications

COEFFICIENT OF UTILIZATION						
pfc pcc pw RCR	20		70		50	
	70	50	30	70	50	30
0	82	82	82	81	81	77 77
1	76	72	70	75	71	68 68 67
2	69	65	59	68	63	58 60 57
3	64	56	52	61	56	51 54 50
4	58	51	45	56	50	45 47 44
5	54	46	40	53	45	39 44 39
6	50	40	35	48	40	34 40 34
7	46	38	32	46	36	32 35 30
8	44	34	28	42	34	28 33 28
9	40	32	26	40	30	26 30 26
10	38	28	23	36	28	23 28 23

LIGHT DISTRIBUTION			
DEGREES	LUMENS	% LAMP	% FIXTURE
0-30	1260	22.1	31.7
0-40	2011	35.3	50.6
0-60	3330	58.4	83.8
0-90	3972	69.7	100.0

.75LLF = .94LDD x .91LLD x .88BF