

# OM6LED - 1500/2000

6" LED 1500/2000 Lumen Vandal Resistant Downlight  
with MesoOptics® & Remote Phosphor

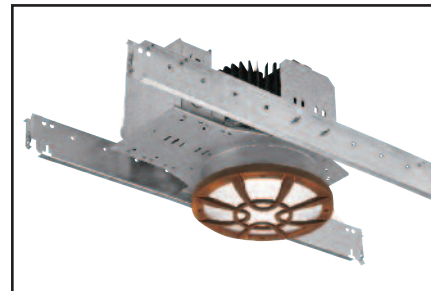

CAT. NO:

TYPE:

PROJECT:

## PRODUCT INFORMATION

**1. Omega mixing chamber/optical assembly:** Remote phosphor technology provides increased efficiency and color stability by redirecting back reflected light. Patented Meso Optic and phosphor lens assembly converts high brightness blue light into white light for an even diffused pattern, eliminating bright spots often created by individual LEDs. This technology provides consistent, stable color with CCT color control of +/- 100K over the life of the light engine and provides 20% higher efficiency.

**2. LED Array:** The LED Array consist of a metal core circuit board with 16 high brightness royal blue LEDs.

**3. Thermal Management:** A proprietary die-cast aluminum heat sink allows for easy and toolless installation to the housing yoke. The heat sink is designed to properly maintain junction temperatures in recessed non-ic applications to provide reliable performance over the life of the light engine. The heat sink incorporates alignment tabs to properly position the heat sink with the housing and rust resistant springs to secure the heat sink and reflector.

**4. Housing:** Precision die stamped 18ga galvanized steel mounting pan and yoke assembly. Allows for ceiling thickness up to 1-3/8". Yoke supports weight of heat sink and light engine assembly to prevent stress on finished reflector.

**5. Reflector:** Precision spun .050 aluminum reflectors are self flanged and snap to heat sink for consistent alignment to the optical assembly. Provides 50 degree visual cutoff to source and source image.

**6. Lifetime/Lumen Maintenance:** 1500 Lumen - 60,000 hour lifetime at 70% lumen maintenance light engine. (L70) 2000 Lumen - 57,000 hour lifetime at 70% lumen maintenance light engine. (L70)

**7. C channels:** Revelation c-channels are included and provide vertical and horizontal adjustments. These allow for fast and adjustment free installation in T-bar ceilings with 1/2" tile. C-channels simply snap on grid for proper alignment in 24" O.C. grid systems.

Canadian Specifications may vary from these shown, consult Canadian Division.

**8. Junction Box:** 16 ga galvanized steel. UL listed for 8 No. 12 AWG, 90C through branch circuit conductors. Allows inspection below ceiling.

**9. Color:** Available in three CCT options, 3000K, 3500K or 4000K with 80CRI +/-2%.

**10. Electrical:** The power supply/driver features Advance Intelli-volt 120-277VAC 50/60hz, with 0-10V analog dimming capability. The power supply is overload and short circuit protected as well as thermally regulated to prevent overheating. Sound rating A. Refer to dimming compatability spec sheet for complete details. Driver has rated lifetime of 50,000 hours. 70C maximum operating temperature, -20C minimum starting temperature.

### 1500 Lumen Package

Input Voltage	Input Current	Drive Current	Input Power	LED Power	THD %	Power Factor
120	0.25	350mA	27	23.1	10%	>0.9
277	0.11	350mA	27	23.1	10%	>0.9

### 2000 Lumen Package

Input Voltage	Input Current	Drive Current	Input Power	LED Power	THD %	Power Factor
120	0.36	520mA	39	35.4	10%	>0.9
277	0.17	520mA	39	35.4	10%	>0.9

**11. Service:** Modular construction allows for easy maintenance of complete system below ceiling. Removing reflector provides easy access to heat sink and light engine assembly. This assembly may be removed by de-pressing the springs which attach to the yoke and then simply opening protective cover and unplugging push in connector from LED board.

**12. ETL, cUL, IBEW** (Suitable for wet locations)

**13. Photometric testing** performed using IESNA - LM79 procedures. LED lifetime testing performed using IESNA - LM80 procedures.

**14. 5 year Warranty**



## CATALOG SYSTEM AND OPTIONS

EXAMPLE OF COMPLETE CATALOG NUMBER: **ORTLED39I20-R6LED30KVGRUIPCL**

### HOUSING - ROUGH IN

Omega 6"	Wattage	Supply Voltage	Option
ORT6LED	27	120	EM - Bodine
	27 input watts	120 VAC	BSLI7C
	39	50/60Hz	Emergency Back-up
	39 input watts	277	
		277 VAC	
		50/60Hz	

### LIGHT ENGINE - REFLECTOR

Omega 6"	CCT	Vandal Guard (optional)	Finishes	Lens
R6LED	30K 3000K	VG	NA Natural Aluminum	IPCL
	35K 3500K	vandal guard	GR Graphite	Clear Lens - IP55
	40K 4000K		PW Pewter	IPPOLY .
			TI Titanium	25" Polycarbonate - IP55
			CO Copper	
			BR Bronze	
			RU Iron Oxide	
			BK Black	
			WH White	
			AL Aluminum	

**FIVE YEAR**  
Warranty

\* Lumen output varies depending on CCT and distribution, refer to specific IES files for details.

DIMENSIONS

6

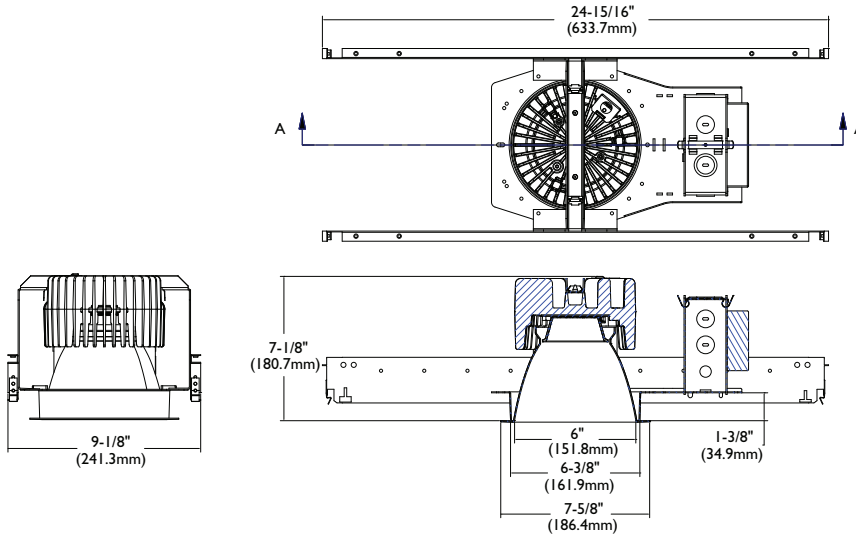

VANDAL GUARD



VG - Vandal Guard  
(RU - iron oxide finish shown)

PHOTOMETRICS

Please consult factory for photometrics.

Additional photometric test files are available @ [omegalighting.com](http://omegalighting.com)



PHILIPS OMEGA  
776 South Green St., Tupelo, MS 38804  
Phone 662.842.7212 FAX 662.841.5501

PHILIPS DAY-BRITE CANADA  
189 Bullock Drive, Markham, Ontario, Canada L3P 1W4  
Phone 905.294.9570 FAX 800.268.0003